

EXL Pillow Blocks & S-1 Units Instruction Manual

These instructions must be read thoroughly before installation or operation. This instruction manual was accurate at the time of printing. Please see dodgeindustrial.com for updated instruction manuals.

WARNING: To ensure the drive is not unexpectedly started, turn off and lock-out or tag power source before proceeding. Failure to observe these precautions could result in bodily injury.

WARNING: All products over 25 kg (55 lbs) are noted on the shipping package. Proper lifting practices are required for these products.

FITTING OR REPLACING A UNIT IN A PILLOW BLOCK

1. Match marks have been stamped on the mating faces of the cap and base of each outer housing. When reassembling pillow block make sure match marks on cap and base align. At this time do not remove shims found between the cap and base.
2. Lubricate bearing seat on the cap and on the base of the outer housing with an anti-seize compound.
3. Fit each unit to its outer housing before carrying out Step 7. Place the unit in the pillow block base and install cap. Tighten cap bolts to specified torque in Table 1.
4. Add or remove shims between cap and base as required to obtain snug fit of unit in outer housing with cap bolts tightened to specified torque in Table 1.
5. Check fit by prying against lubrication stud in unit through the lubrication hole in housing cap with a screwdriver or small pinch bar depending upon the size of the pillow blocks.
6. The snug fit becomes a matter of judgment. A loose or sloppy fit may allow a unit mount to move in its outer housing thus wearing the mating surfaces. Too tight a fit will not allow the unit to move and compensate for misalignment and for shaft deflection caused by belt pull and dead weight.
7. Install bearings per installation instructions on following pages.

WARNING: Because of the possible danger to person(s) or property from accidents which may result from the improper use of products, it is important that correct procedures be followed. Products must be used in accordance with the engineering information specified in the catalog. Proper installation, maintenance and operation procedures must be observed. The instructions in the instruction manuals must be followed. Inspections should be made as necessary to assure safe operation under prevailing conditions. Proper guards and other suitable safety devices or procedures as may be desirable or as may be specified in safety codes should be provided, and are neither provided by Dodge® nor are the responsibility of Dodge. This unit and its associated equipment must be installed, adjusted and maintained by qualified personnel who are familiar with the construction and operation of all equipment in the system and the potential hazards involved. When risk to persons or property may be involved, a holding device must be an integral part of the driven equipment beyond the speed reducer output shaft.

Table 1 - Cap Bolt Torque (Grade 8 Bolts)

Bore Size (in.)	2 - Bolt Base		4 - Bolt Base	
	Bolt Size	Torque (ft. - lbs.)	Bolt Size	Torque (ft. - lbs.)
1-3/16-1-1/4	5/16-18	20-25	-	-
1-3/8-1-7/16	3/8-16	35-45	-	-
1-1/2-1-11/16	3/8-16	35-45	-	-
1-3/4-2	7/16-14	55-70	-	-
2-3/16	7/16-14	55-70	-	-
2-1/4-2-1/2	1/2-13	85-110	1/2-13	85-110
2-11/16-3	1/2-13	85-110	1/2-13	85-110
3-3/16-3-1/2	5/8-11	170-210	5/8-11	170-210
3-15/16-4	-	-	5/8-11	170-210
4-7/16-4-1/2	-	-	3/4-10	300-380
4-15/16-5	-	-	3/4-10	300-380

INSTALLATION OF BEARINGS

1. Shaft must be clean, free of burrs and lubricated. File nicks from housing bases.
2. Loosen setscrews in collar and slide bearings on shaft. If force is necessary, tap inner race only with a light drift. For vertical applications, locate adjusting nut on bearing so nut faces upward.
3. Position expansion (floating) pillow block on mounting surface and tighten base hold-down bolts. (Use Grade 8 bolts for heavy loads.)
4. Position non-expansion (fixed) pillow block in correct relation to shaft and mounting surface. Tighten base hold-down bolts. (Use Grade 8 bolts for heavy loads.) Then torque setscrews in collar per Table 2.

Table 2 - Set Screw Torque

Bore Size (in.)	Set Screw Size	In-lbs.
1-3/16-1-11/16	5/16	165
1-3/4-2-1/2	3/8	290
2-11/16-3-1/2	1/2	620
3-15/16-5	5/8	1325
5-7/16-6	3/4	2150
6-7/16-7	7/8	5130

5. The effort required to turn the shaft should be the same before and after bolting bearings to the support.
6. Mount a dial indicator on the shaft near the non-expansion (fixed) bearing. Place the indicator probe so that it contacts the machined surface of the S-1 Unit Housing perpendicular to that surface. See Figure 1. Note that only one face of the S-1 unit is machined.
7. Zero the indicator and sweep the machined face 360°, noting the total indicator turnout (TIR).
8. If the TIR is less than or equal to the value shown on Table 3, tighten the housing cap bolts per Table 1.
9. If the TIR is greater than shown on Table 3, gently tap the machined face of the S-1 housing until the TIR is less than or equal to the value shown on Table 3. Then torque the housing cap bolts per Table 1. Sweep machined faces again to verify that the TIR is still less than or equal to the value shown on Table 3.

Table 3 – Total Indicator Run-Out (TIR)

Bore Size (in.)	TIR (Inches)
1-3/16 – 1-1/4	0.0028
1-3/8 – 1-7/16	0.0030
1-1/2 – 1-11/16	0.0035
1-3/4 – 2	0.0040
2-3/16	0.0040
2-1/4 – 2-1/2	0.0045
2-11/16 – 3	0.0055
3-3/16 – 3-1/2	0.0065
3-15/16 – 4	0.0070
4-7/16 – 4-1/2	0.0080
4-15/16 – 5	0.0085

10. The non-expansion (fixed) bearing is now installed. Move to the expansion (floating) bearing.
11. Locate expansion unit in center of its axial travel or at extreme if maximum expansion is required (do not preload stop pin) and torque collar setscrews per Table 2.
12. Do not install external grease fittings until completion of final steps below.
13. Torque setscrews of expansion unit (Table 2).
14. Repeat steps 6, 7, 8 and 9 for the expansion bearing.
15. The expansion (floating) bearing is now installed.

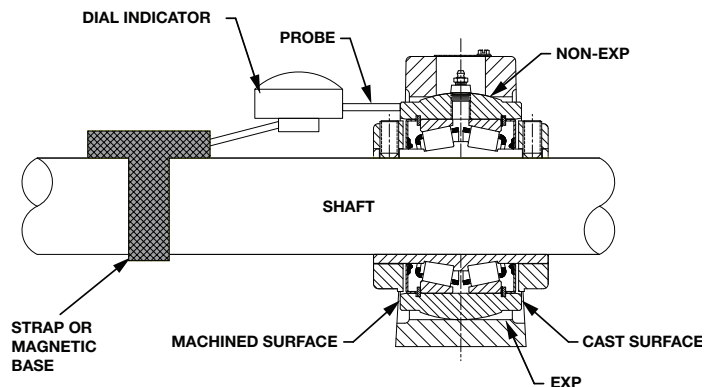

Figure 1 - Mounting Diagram

LUBRICATION GUIDELINES

This bearing is factory lubricated with a lithium or lithium complex base grease which is suitable for most applications. However, extra protection is necessary if the bearing is subjected to excessive moisture, dust, corrosive vapor or other harsh environments. In these cases, the bearing should contain as much grease as speed will permit (a full bearing with consequent slight leakage through the seal is the best protection against contaminant entry).

For relubrication, select a grease that is compatible with a lithium or lithium complex grease. The following table is a general guide for normal operating conditions. However, some situations may require a change in lubricating periods as dictated by experience.

Normal Operation — This bearing has been greased at the factory and is ready to run. The following table is a general guide for re-lubrication. However, certain conditions may require a change of lubricating periods as dictated by experience. See “High Speed Operation” and “Operation in Presence of Dust, Water or Corrosive Vapors” sections.

High Speed Operation — High speed operation is 70% of maximum catalog speed and above. In the higher speed ranges too much grease will cause overheating. The amount of grease that the bearing will take for a particular high speed application can only be determined by experience — see “Operating Temperature” below. If excess grease in the bearing causes overheating, it will be necessary to remove grease fitting (also drain plug when furnished) to permit excess grease to escape. The bearing has been greased at the factory and is ready to run. When establishing a re-lubrication schedule, note that a small amount of grease at frequent intervals is preferable to a large amount at infrequent intervals.

Operation in Presence of Dust, Water or Corrosive Vapors — Under these conditions the bearing should contain as much grease as speed will permit, since a full bearing with consequent slight leakage is the best protection against entrance of foreign material. In the higher speed ranges too much grease will cause overheating— see “High Speed Operation” above. In the lower speed ranges it is advisable to add extra grease to a new bearing before putting into operation. Bearings should be greased as often as necessary (daily if required) to maintain a slight leakage at the seals.

Operating Temperature — Abnormal bearing temperature may indicate faulty lubrication. Normal temperature may range from a few degrees up to 100°F above ambient, depending on bearing size, speed, loading and environmental conditions. Unusually high temperature, in this range, accompanied by excessive leakage of grease indicates too much grease. In the circumstance that there is excess grease in the bearing, remove the grease fitting to allow the excess grease to purge. When purging ceases, wipe excess grease with a clean rag and screw fitting back into the bearing. High temperature with no grease showing at the seals, particularly if the bearing seems noisy, usually indicates too little grease. Normal temperature and a slight showing of grease at the seals indicate proper lubrication.

LUBRICATION GUIDE

Read preceding paragraphs before establishing lubrication schedule.

Table 4 – Suggested Lubrication Period in Weeks

Hours Run Per Day	1–250 RPM	251–500 RPM	501–750 RPM	751–1000 RPM	1001–1500 RPM
8	12	12	10	7	5
16	12	7	5	4	2
24	10	5	3	2	1

Lubrication recommendations are intended for standard products applied in general operating conditions. For modified products, high temperature environments and other anomalous applications, contact product engineering at (864)284-5700.

Kind of Grease — Many ordinary cup greases will disintegrate at speeds far below those at which Dodge bearings will operate successfully if proper grease is used. Standard Dodge bearings have been lubricated at the factory with a NLGI #2 lithium complex base grease. Relubricate with lithium-base or lithium complex base grease, or a grease which is compatible with original lubricant and suitable for roller bearing service. In unusual or doubtful cases the recommendation of a reputable grease manufacturer should be secured.

Storage or Special Shutdown — If exposed to wet or dusty conditions or to corrosive vapors, extra protection is necessary. Add grease until it shows at the seals; rotate the bearing to distribute grease; cover the bearing. After storage or idle period, add a little fresh grease before running. During long idle periods, rotate shaft at least once a month.

Special Operating Conditions — Refer acid, chemical, extreme or other special operating conditions to Dodge Industrial Product Support in Greenville SC at +1 864 284 5700.

Successful operation is dependent upon adequate lubrication. Precaution should be taken during handling and recycling grease, oil, or water glycol mixtures.

Table 5 – EXL Pillow Block Assemblies and Replacement S-1 Units

Shaft Size	Non-Expansion				Expansion				S-1 Unit	
	2-Bolt Pillow Block Assy PN		4-Bolt Pillow Block Assy PN		2-Bolt Pillow Block Assy PN		4-Bolt Pillow Block Assy PN			
1 3/16	077221	P2B-EXL-103R	-	-	077244	P2B-EXL-103RE	-	-	077192	S1U-EXL-103R
1 1/4	077222	P2B-EXL-104R	-	-	077245	P2B-EXL-104RE	-	-	077193	S1U-EXL-104R
1 3/8	077223	P2B-EXL-106R	-	-	077246	P2B-EXL-106RE	-	-	077194	S1U-EXL-106R
1 7/16	077224	P2B-EXL-107R	-	-	077247	P2B-EXL-107RE	-	-	077195	S1U-EXL-107R
1 1/2	077225	P2B-EXL-108R	-	-	077248	P2B-EXL-108RE	-	-	077196	S1U-EXL-108R
1 5/8	077226	P2B-EXL-110R	-	-	077249	P2B-EXL-110RE	-	-	077197	S1U-EXL-110R
1 11/16	077227	P2B-EXL-111R	-	-	077250	P2B-EXL-111RE	-	-	077198	S1U-EXL-111R
1 3/4	077228	P2B-EXL-112R	-	-	077251	P2B-EXL-112RE	-	-	077199	S1U-EXL-112R
1 7/8	077229	P2B-EXL-114R	-	-	077252	P2B-EXL-114RE	-	-	077200	S1U-EXL-114R
1 15/16	077230	P2B-EXL-115R	-	-	077253	P2B-EXL-115RE	-	-	077201	S1U-EXL-115R
2	077231	P2B-EXL-200R	-	-	077254	P2B-EXL-200RE	-	-	077202	S1U-EXL-200R
2 3/16	077232	P2B-EXL-203R	-	-	077255	P2B-EXL-203RE	-	-	077203	S1U-EXL-203R
2 1/4	077233	P2B-EXL-204R	077267	P4B-EXL-204R	077256	P2B-EXL-204RE	077284	P4B-EXL-204RE	077204	S1U-EXL-204R
2 7/16	077234	P2B-EXL-207R	077268	P4B-EXL-207R	077257	P2B-EXL-207RE	077285	P4B-EXL-207RE	077205	S1U-EXL-207R
2 1/2	077235	P2B-EXL-208R	077269	P4B-EXL-208R	077258	P2B-EXL-208RE	077286	P4B-EXL-208RE	077206	S1U-EXL-208R
2 11/16	077236	P2B-EXL-211R	077270	P4B-EXL-211R	077259	P2B-EXL-211RE	077287	P4B-EXL-211RE	077207	S1U-EXL-211R
2 3/4	077237	P2B-EXL-212R	077271	P4B-EXL-212R	077260	P2B-EXL-212RE	077288	P4B-EXL-212RE	077208	S1U-EXL-212R
2 15/16	077238	P2B-EXL-215R	077272	P4B-EXL-215R	077261	P2B-EXL-215RE	077289	P4B-EXL-215RE	077209	S1U-EXL-215R
3	077239	P2B-EXL-300R	077273	P4B-EXL-300R	077262	P2B-EXL-300RE	077290	P4B-EXL-300RE	077210	S1U-EXL-300R
3 3/16	077240	P2B-EXL-303R	077274	P4B-EXL-303R	077263	P2B-EXL-303RE	077291	P4B-EXL-303RE	077211	S1U-EXL-303R
3 1/4	077241	P2B-EXL-304R	077275	P4B-EXL-304R	077264	P2B-EXL-304RE	077292	P4B-EXL-304RE	077212	S1U-EXL-304R
3 7/16	077242	P2B-EXL-307R	077276	P4B-EXL-307R	077265	P2B-EXL-307RE	077293	P4B-EXL-307RE	077213	S1U-EXL-307R
3 1/2	077243	P2B-EXL-308R	077277	P4B-EXL-308R	077266	P2B-EXL-308RE	077294	P4B-EXL-308RE	077214	S1U-EXL-308R
3 15/16	-	-	077278	P4B-EXL-315R	-	-	077295	P4B-EXL-315RE	077215	S1U-EXL-315R
4	-	-	077279	P4B-EXL-400R	-	-	077296	P4B-EXL-400RE	077216	S1U-EXL-400R
4 7/16	-	-	077280	P4B-EXL-407R	-	-	077297	P4B-EXL-407RE	077217	S1U-EXL-407R
4 1/2	-	-	077281	P4B-EXL-408R	-	-	077298	P4B-EXL-408RE	077218	S1U-EXL-408R
4 15/16	-	-	077282	P4B-EXL-415R	-	-	077299	P4B-EXL-415RE	077219	S1U-EXL-415R
5	-	-	077283	P4B-EXL-500R	-	-	077300	P4B-EXL-500RE	077220	S1U-EXL-500R

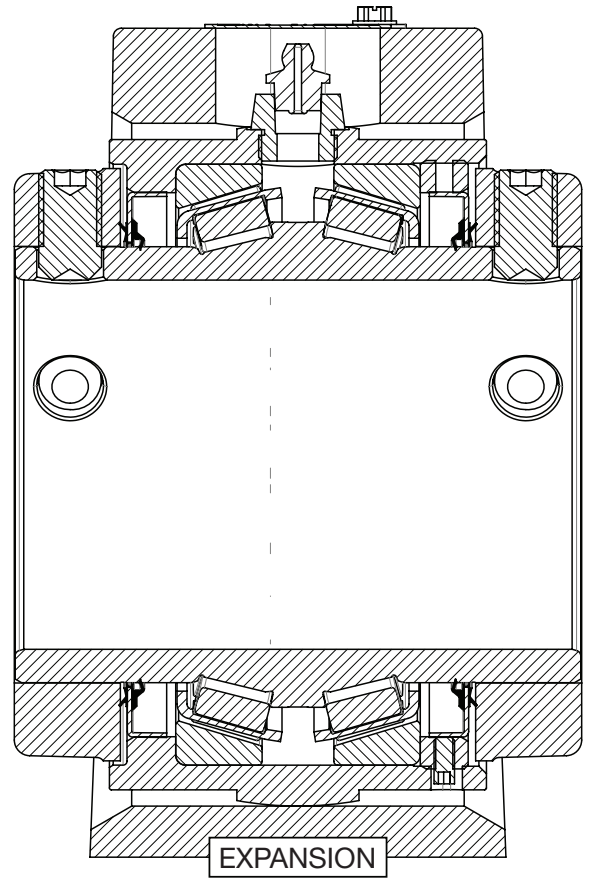
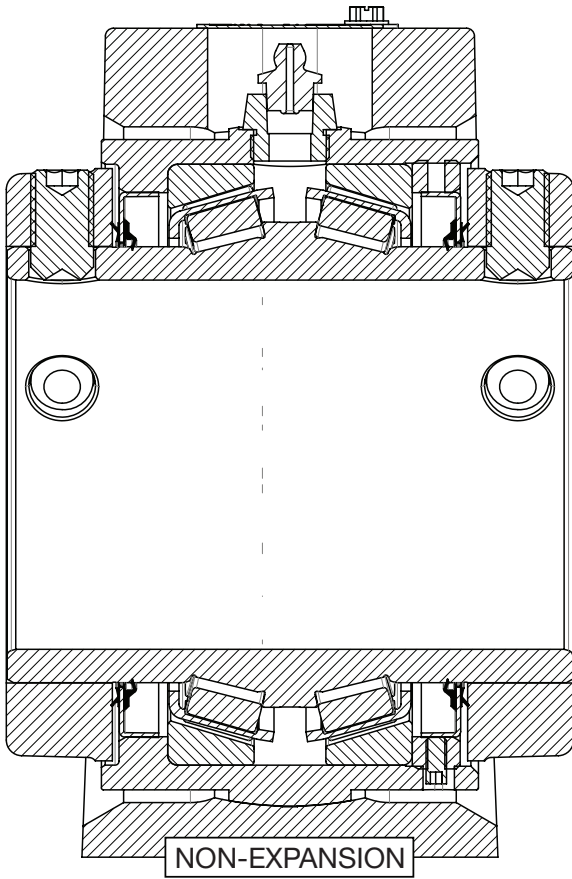

Figure 2 - EXL Non-Expansion and Expansion Cross Sections

Dodge Industrial, Inc.
1061 Holland Road
Simpsonville, SC 29681
+1 864 297 4800

