

## S-2000 Spherical Roller Bearings Instruction Manual

These instructions must be read thoroughly before installation or operation. This instruction manual was accurate at the time of printing. Please see [dodgeindustrial.com](http://dodgeindustrial.com) for updated instruction manuals.

**WARNING:** To ensure the drive is not unexpectedly started, turn off and lock-out or tag power source before proceeding. Failure to observe these precautions could result in bodily injury.

**WARNING:** All products over 25 kg (55 lbs) are noted on the shipping package. Proper lifting practices are required for these products.

### INSTALLATION

#### GENERAL INFORMATION

S-2000 Spherical Roller Bearing mounted units incorporate a unique way of sealing the internal components of the bearing while still allowing a full + or - 1 degree of misalignment. The patented sealing system (Pat. #5,908,249) has proven effective, due to its constant contact pressure, in protecting the internal bearing components under maximum allowable misaligned conditions.

#### NON-EXPANSION BEARING

1. Clean shaft and bore of bearing. The shaft should be straight, free of burrs and nicks, and correct size (see shaft tolerance table). If used shafting is utilized, then the bearing should be mounted on unworn section of shafting.
2. Lubricate shaft and bearing bore with grease or oil to facilitate assembly. Slip bearing into position. When light press fit is required, press against the end of the inner ring of bearing. Do not strike or exert pressure on the housing or seals.
3. Bolt bearing to support, using shims where necessary to align bearing so inner ring does not rub on seal carrier. Use full shims which extend across the entire housing base.
4. Determine final shaft position and tighten setscrews in the locking collar(s) of non-expansion bearing to recommended torque while the other bearings remain free. Rotate the shaft slowly under load, if possible, to properly center the rolling elements with respect to the raceways. Then tighten

**WARNING:** Because of the possible danger to person(s) or property from accidents which may result from the improper use of products, it is important that correct procedures be followed. Products must be used in accordance with the engineering information specified in the catalog. Proper installation, maintenance and operation procedures must be observed. The instructions in the instruction manuals must be followed. Inspections should be made as necessary to assure safe operation under prevailing conditions. Proper guards and other suitable safety devices or procedures as may be desirable or as may be specified in safety codes should be provided, and are neither provided by Dodge® nor are the responsibility of Dodge. This unit and its associated equipment must be installed, adjusted and maintained by qualified personnel who are familiar with the construction and operation of all equipment in the system and the potential hazards involved. When risk to persons or property may be involved, a holding device must be an integral part of the driven equipment beyond the speed reducer output shaft.

setscrews into the locking collar of the remaining bearings to the recommended torque.

5. Check rotation. If there is any strain, irregular rotational torque or vibration, it could be due to incorrect alignment, bent shaft or bent supports. Installation should be rechecked and correction made where necessary.

#### EXPANSION BEARING

1. Clean shaft and bore of bearing. The shaft should be straight, free of burrs and nicks, and correct size (see shaft tolerance table). If used shafting is utilized, then the bearing should be mounted on unworn section of shafting.
2. Lubricate shaft and bearing bore with grease or oil to facilitate assembly. Slip bearing into position. When light press fit is required, press against the end of the inner ring of bearing. Do not strike or exert pressure on the housing or seals.
3. Bolt bearing to support, using shims where necessary to align bearing so inner ring does not rub on seal carrier. Use full shims which extend across the entire housing base.
4. Position expansion bearing in the housing. For normal expansion conditions, the bearing insert should be positioned in the center of the housing. To center bearing insert in housing, move bearing insert to extreme position and mark shaft. Then using bearing maximum total expansion table, move bearing insert in opposite direction one-half the total expansion to center bearing in the housing. If maximum expansion is required, move bearing insert to the extreme position in the housing to permit full movement in direction of expansion. After expansion bearing has been positioned in the housing, tighten the setscrews in the locking collar to the recommended torque.
5. Check rotation. If there is any strain, irregular rotational torque or vibration, it could be due to incorrect alignment, bent shaft or bent supports. Installation should be rechecked and correction made where necessary.

#### FIELD CONVERSION (RE-OP) OF A NON-EXPANSION BEARING INTO AN EXPANSION BEARING

All non-expansion bearing sizes can be re-oped to become expansion bearings. To re-op a non-expansion to an expansion bearing follow these steps:

1. Move the snap ring, opposite from the collar side of bearing, to the outermost snap ring groove.
2. Install bearing per Expansion Bearing instructions listed above.

**NOTE: Bearing nameplate has a non-expansion Part Number. When bearing is re-oped the bearing should be marked as expansion for future reference.**

| Shaft Size (in.) | Total Expansion (in.) |
|------------------|-----------------------|
| 1-3/8 – 1 1/2    | 3/16                  |
| 1-11/16 – 3 7/16 | 1/14                  |
| 3-15/16          | 5/16                  |
| 4-7/16 – 4 15/16 | 3/8                   |

## LUBRICATION INSTRUCTIONS

### OPERATION IN PRESENCE OF DUST, WATER OR CORROSION VAPORS

This bearing is factory lubricated with No. 2 consistency lithium complex base grease which is suitable for most applications. However, extra protection is necessary if bearing is subjected to excessive moisture, dust, or corrosive vapor. In these cases, bearing should contain as much grease as speed will permit (a full bearing with consequent slight leakage through the seal is the best protection against contaminant entry).

In extremely dirty environments, the bearing should be purged daily to flush out contaminants. For added protection, it is advisable to shroud the bearing from falling material.

### HIGH SPEED OPERATION

At higher operation speeds, too much grease may cause overheating. In these cases, the amount of lubrication can only be determined by experience. If excess grease causes overheating, remove grease fittings and run for ten minutes. This will allow excess grease to escape. Then wipe off excess grease and replace grease fittings.

In higher speed applications, a small amount of grease at frequent intervals is preferable to a large amount at infrequent intervals. However, the proper volume and interval of lubrication can best be determined by experience.

### AVERAGE OPERATIONS

The following table is a general guide for normal operating conditions. However, some situations may require a change in lubricating periods as dictated by experience. If the bearing is exposed to unusual operating conditions, consult a reputable grease manufacturer.

## LUBRICATION GUIDE

Read preceding paragraphs before establishing lubrication schedule

| Hours run per day | 1 to 250 rpm | 251 to 500 rpm | 501 to 750 rpm | 751 to 1500 rpm | 1001 to 2000 rpm | 1501 to 2000 rpm | 2001 to 2500 rpm | 2501 to 3000 rpm |
|-------------------|--------------|----------------|----------------|-----------------|------------------|------------------|------------------|------------------|
| 8                 | 12           | 12             | 10             | 7               | 5                | 4                | 3                | 2                |
| 16                | 12           | 7              | 5              | 4               | 2                | 2                | 2                | 1                |
| 24                | 10           | 5              | 3              | 2               | 1                | 1                | 1                | 1                |

## OPERATING TEMPERATURE

Abnormal bearing temperatures may indicate insufficient lubrication. If the housing is too hot to touch for more than a few seconds, check the temperature by applying a thermometer at the top of the pillow block with the thermometer tip surrounded by putty.

Because the thermometer reading will be approximately 10 °F lower than the actual bearing temperature, add ten degrees to the reading and compare to the temperature rating of your grease. If the bearing temperature reading is consistent and operating within the recommended limits of your grease, the bearing is operating satisfactorily. The recommended maximum operating temperature for S-2000 Spherical Roller Bearings is 200 °F.

## STORAGE OR SPECIAL SHUT DOWN

If equipment will be idle for some time, before shutting down, add grease to the bearing until grease purges from the seals. This will ensure protection of the bearing, particularly when exposed to severe environmental conditions. After storage or idle period, add fresh grease to the bearing before starting.

| Shaft Size            | Socket Set Screw Size | Tightening Torque |
|-----------------------|-----------------------|-------------------|
| 1-3/8 – 1-3/4 in.     | 5/16 in.              | 165 Inch Pounds   |
| 1-15/16 – 2-7/16 in.  | 3/8 in.               | 290 Inch Pounds   |
| 2-11/16 – 3-7/16 in.  | 1/2 in.               | 620 Inch Pounds   |
| 3-15/16 – 4-15/16 in. | 5/8 in.               | 1325 Inch Pounds  |

| Normal Shaft Size       | Low to Normal Equivalent Load and Catalog Speed* |             |
|-------------------------|--|-------------|
| Up to 1-1/2 in.         | +0.000 in.                                       | -0.0005 in. |
| Over 1-1/2 to 2-1/2 in. | +0.000 in.                                       | -0.001 in.  |
| Over 2-1/2 to 4 in.     | +0.000 in.                                       | -0.001 in.  |
| Over 4 to 5 in.         | +0.000 in.                                       | -0.0015 in. |

\*Normal equivalent load .08C to .18C.

On severe applications and where dynamic balance and minimum runout are important, a snug to light press fit may be required to obtain optimum bearing performance. Consult Dodge Product Support.

# S-2000 PARTS COMPONENTS

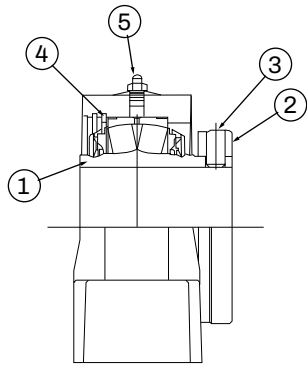

2 Bolt Pillow Block S2000-R

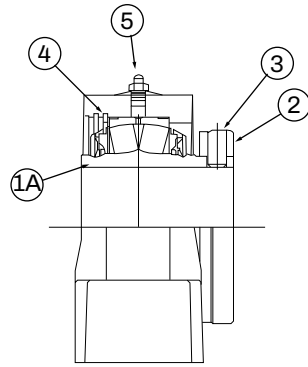

2 Bolt Pillow Block S2000-L

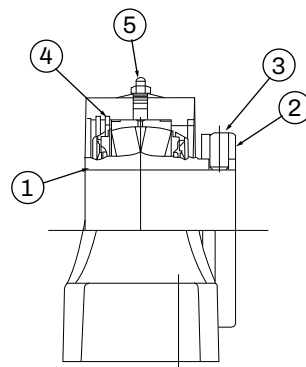

4 Bolt Pillow Block S2000-R

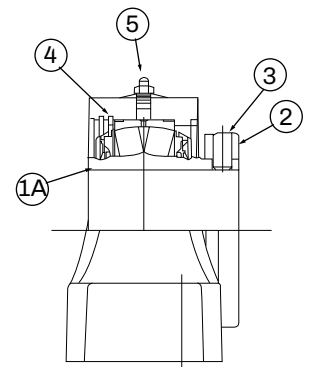

4 Bolt Pillow Block S2000-L

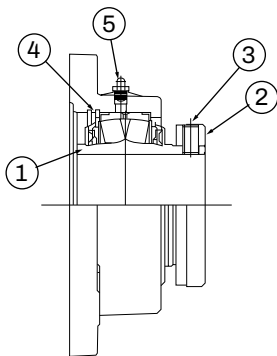

3 & 4 Bolt Round Flange S2000-R

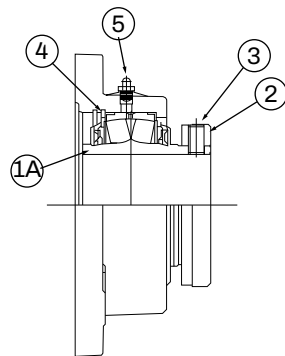

3 & 4 Bolt Round Flange S2000-L

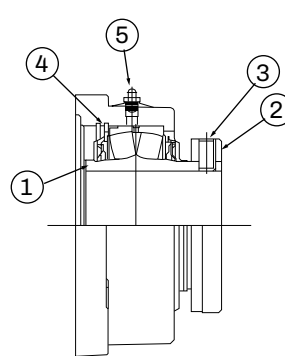

4 Bolt Square Flange S2000-R

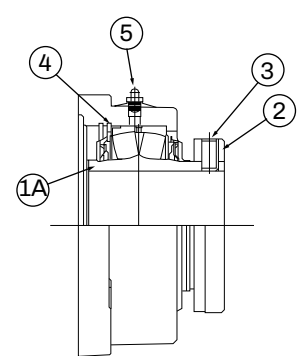

4 Bolt Square Flange S2000-L

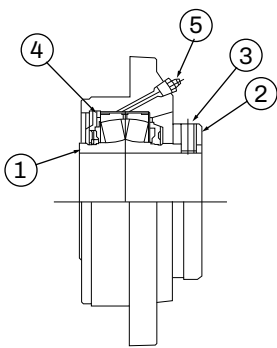

Piloted Flange S2000-R

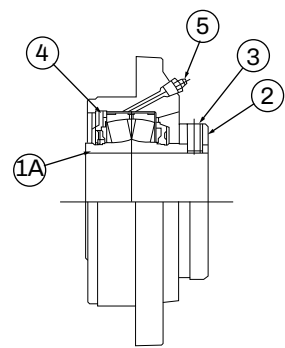

Piloted Flange S2000-L

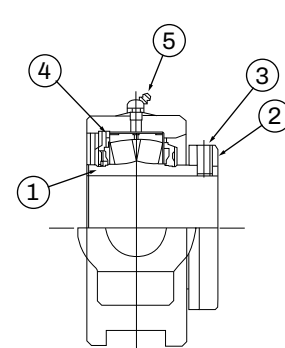

Wide Slot Take-up S2000-R

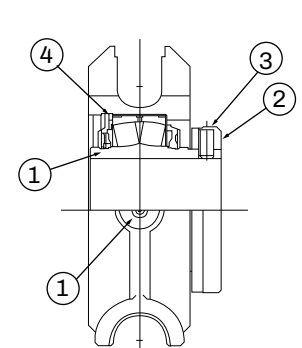

TPHU Take-up S2000-R

| Component Part Numbers (1 3/8" - 4 15/16")  |                                  |                                 |          |            |           |                  |
|---|----------------------------------|---------------------------------|----------|------------|-----------|------------------|
| ITEM  | 1                                | 1A                              | 2        | 3          | 4         | 5                |
| Shaft Size  | Bearing Insert Assembly (R) Seal | Bearing Inert Assembly (L) Seal | *Collar  | *Set Screw | Snap Ring | **Grease Fitting |
| 1 3/8   | 070000                           | 070016                          | 040050   | 400058     | 069276    | 405015           |
| 1 7/16  | 070001                           | 070017                          | 040050   | 400058     | 069276    | 405015           |
| 1 1/2   | 070002                           | 070018                          | 040050   | 400058     | 069276    | 405015           |
| 1 11/16   | 070003                           | 070019                          | 040051   | 400058     | 069277    | 405015           |
| 1 3/4   | 070004                           | 070020                          | 040051   | 400058     | 069277    | 405015           |
| 1 15/16   | 070005                           | 070021                          | 070587   | 400094     | 069278    | 405015           |
| 2   | 070006                           | 070022                          | 070587   | 400094     | 069278    | 405015           |
| 2 3/16  | 070007                           | 070023                          | 070588   | 400094     | 069279    | 405015           |
| 2 7/16  | 070008                           | 070024                          | 040054   | 400094     | 069280    | 405015           |
| 2 11/16   | 070009                           | 070025                          | 070589   | 400150     | 069281    | 405015           |
| 2 15/16   | 070010                           | 070026                          | 070589   | 400150     | 069281    | 405015           |
| 3   | 070011                           | 070027                          | 070589   | 400150     | 069281    | 405015           |
| 3 7/16  | 070012                           | 070028                          | 040056   | 400154     | 069282    | 405015           |
| 3 15/16   | 070013                           | 070029                          | 060946   | 400186     | 069283    | 405015           |
| 4 7/16  | 070014                           | 070030                          | * 060947 | * 400186   | 069284    | 405015           |
| 4 15/16   | 070015                           | 070031                          | * 040059 | * 400190   | 069285    | 405015           |
| QTY/PER   | 1                                | 1                               | 1        | 2          | 1         | 1                |
| *Shaft sizes 4 7/16" - 4 15/16" have two collars a<br>** WSTU and TPHU TU take a 405016 grease fitting. |                                  |                                 |          |            |           |                  |

Dodge Industrial, Inc.  
1061 Holland Road  
Simpsonville, SC 29681  
+1 864 297 4800

